

Woodworking Plans

Measuring Up

Level 1

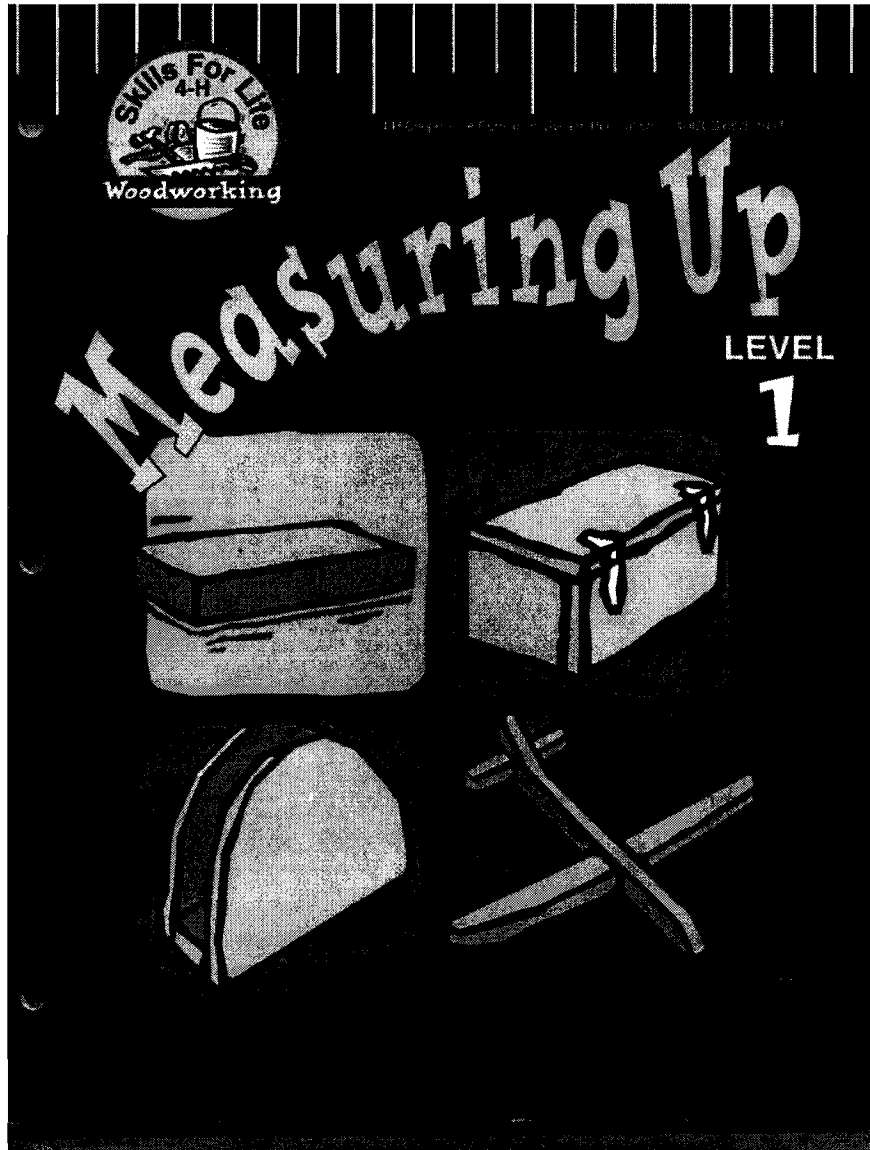

Purdue University, Indiana Counties and U.S.
Department of Agriculture Cooperating
An Affirmative Action/Equal Opportunity Institution

BOX HOCKEY

Materials Needed:

- 1 piece of 5/8" x 30" x 6 feet exterior-grade plywood for floor
- 1 piece lumber 2 x 6 (actual size 1 1/2" x 5 1/2") 8 feet long for ends and partition
- 2 pieces lumber 1 x 6 (actual size 3/4" x 5 1/2") 6 feet long for sides
- 2 pieces lumber 1 x 2 (actual size 3/4" x 1 1/2") 30" long for sticks
- 1 puck—1" thick, 2" diameter
- 12—No. 6, 1 1/4" flathead wood screws
- 36—1 1/2" finishing nails
- Sandpaper
- Paint or varnish

Tools Needed:

- Crosscut saw
- Coping saw
- Pencil compass
- Square
- Countersink
- Claw hammer
- Drill with 1/8" bit
- Paint brush

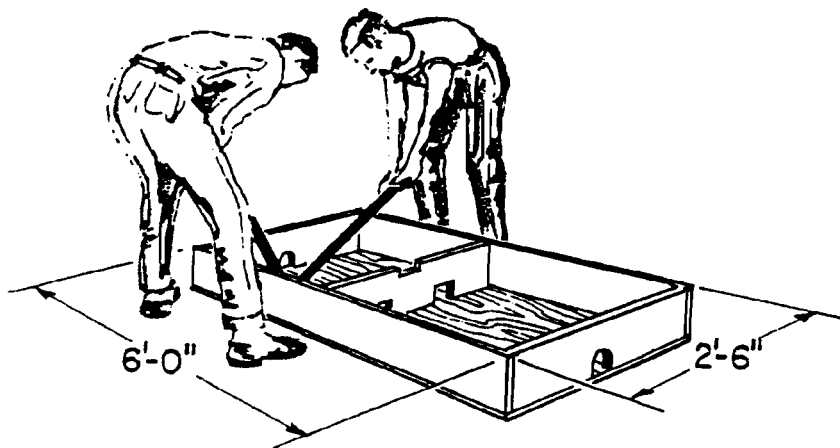
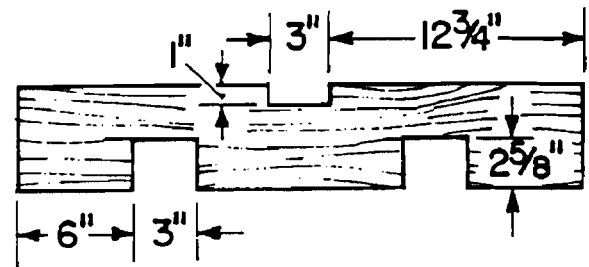
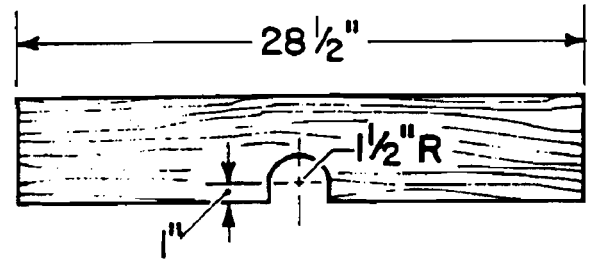

How to Play Box Hockey:

Players stand on opposite sides of box which is placed on the floor. Each player has a hockey stick and holds it at the end. The puck is placed in the notch in the center partition. To start the game, the players "shinny off." (i.e., They touch the bottom of the box and then each other's stick three times, counting 1-2-3 go.) The object of the game is to knock the puck out of the box through the end opening to the player's own left. When the puck goes through opening, the players start over. Best two out of three goals win.

TISSUE DISPENSER

(Plan provided by Bill, Dan, and Bob Beaudreau of Fond du Lac County)

Use as a dispenser over a standard 200 count tissue box. Before building, measure the tissue box that will be used. The inside of the box should be at least $\frac{1}{8}$ " deeper, $\frac{1}{4}$ " wider, and $\frac{1}{4}$ " longer than the tissue box. The inside of this one is $2\frac{5}{8}$ " deep, 5" wide, and $9\frac{3}{4}$ " long.

Materials Needed:

- $\frac{3}{8}$ " material to make:
 - 2 - $\frac{3}{8}$ " x $2\frac{5}{8}$ " x 5" (actual dimensions) for ends
 - 2 - $\frac{3}{8}$ " x $2\frac{5}{8}$ " x $10\frac{1}{2}$ " (actual dimensions) for sides (inside dimension, plus 2 times thickness of end piece)
- $\frac{1}{2}$ " material to make top ($\frac{3}{8}$ " will work)
- 1 - $\frac{1}{2}$ " x $5\frac{3}{4}$ " x $10\frac{1}{2}$ " (actual dimensions) for top
- $\frac{3}{4}$ " wire brads
- Glue
- Finish materials

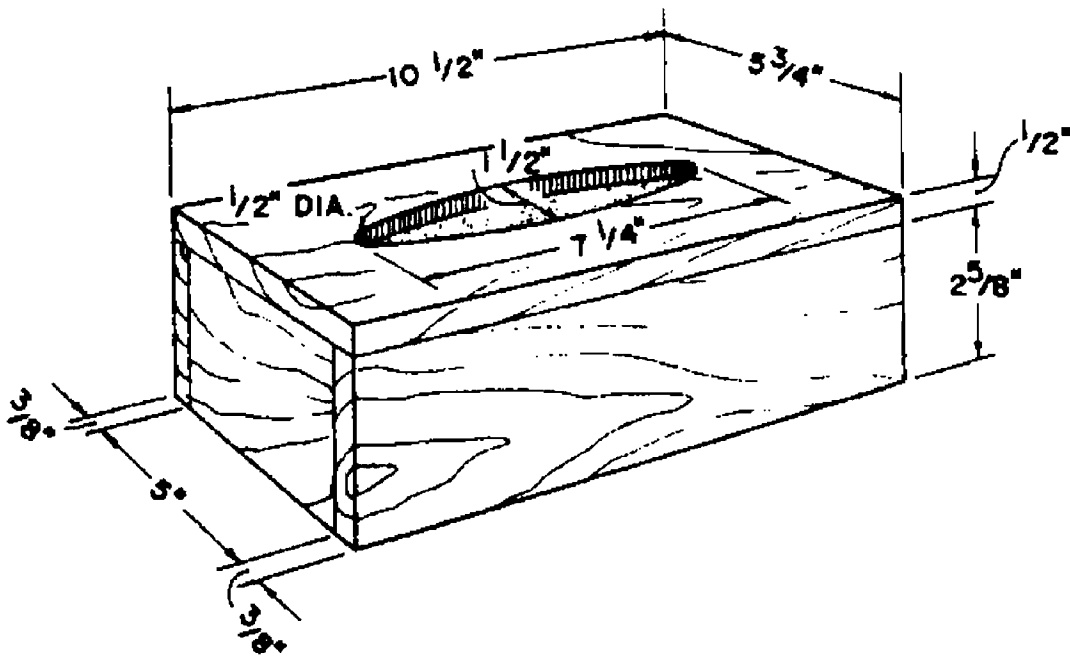

CASSEROLE HOLDERS

To make a casserole holder, use $\frac{3}{4}$ " hardwood stock for the ends and handles and $\frac{1}{2}$ " dowel rods for the rack. The ends are 3" high and should be 2" longer than the width of the baking dish. The handles measure 4" shorter than the ends and are 1" wide. On the inside of the ends, drill $\frac{1}{2}$ " diameter x $\frac{1}{2}$ " deep holes for six dowel rods (see diagram for approximate location). On the outside of the end pieces, drill $\frac{1}{2}$ " dowel rod holes for the handles. Round off all edges on the ends and handles using a rasp and sandpaper. Cut the dowel rods to the length required and assemble the project with glue and clamps.

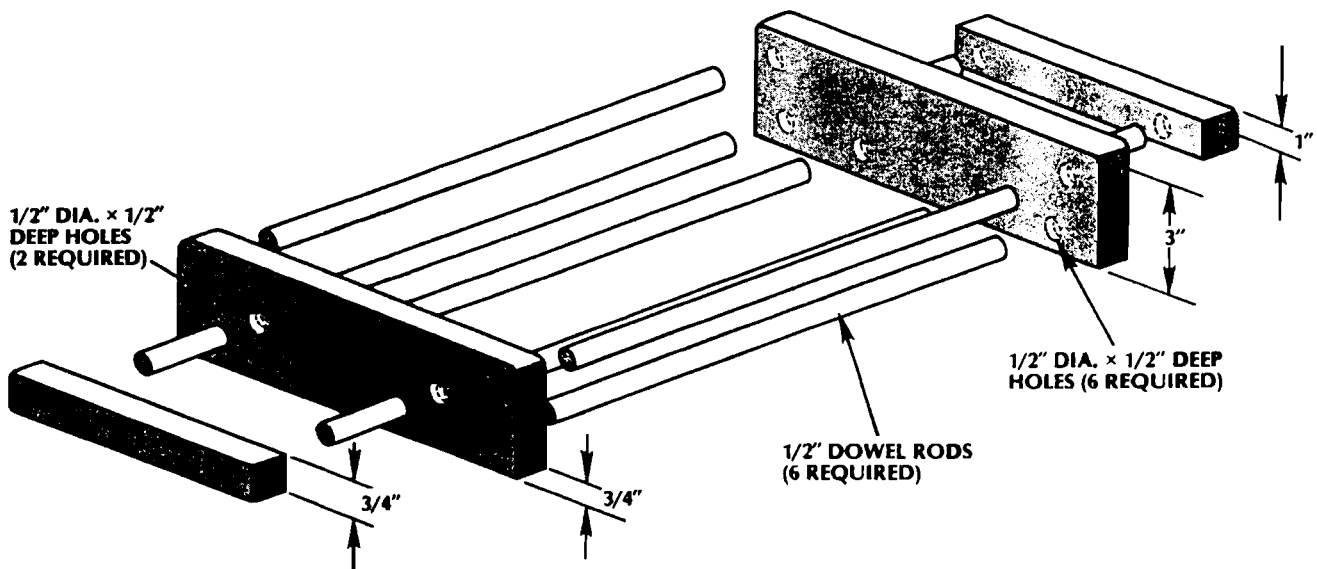

COOLING RACKS

Here are some simple and beautiful cooling racks that you can make in the time it takes to bake a loaf or two.

Cut the sides to length using hardwood from your scrap pile. Drill the 3/8" diameter x 1/4" deep holes in the sides for the dowel rods. Sand the sides and round all the edges by sanding with sandpaper. Next, lightly sand dowel rods, then cut them to length using a hand saw. Assemble the rack with glue and clamp it with bar clamps. Apply a nontoxic finish or leave natural.

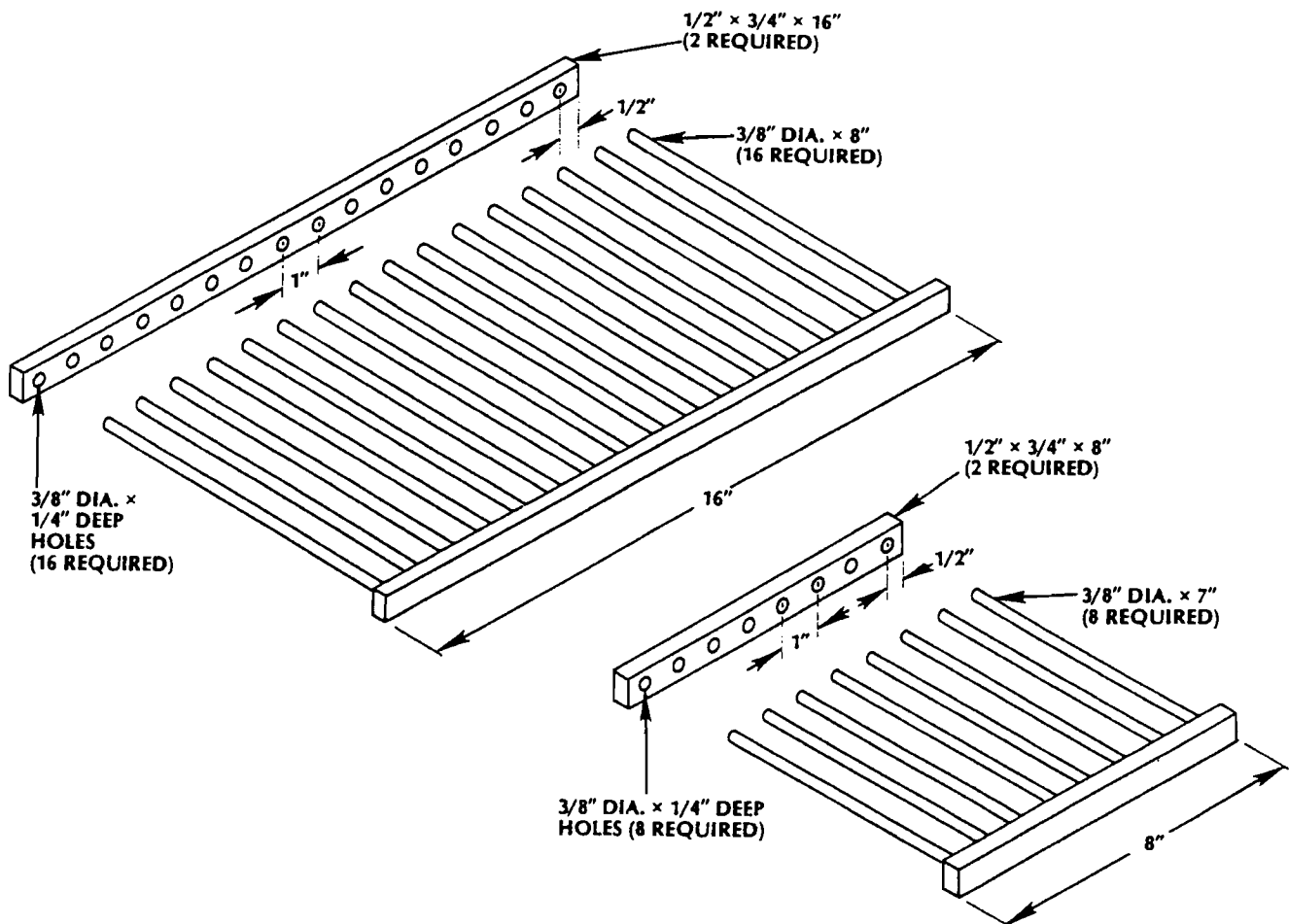

GARDEN TOOL BOX

Here's a handy carrier for your garden tools that's a cinch to put together. The toolbox is equally useful for the plumber, electrician, or mechanic in your home.

List of Materials:

(finished dimensions in inches)

A	Bottom	1/4 x 7 x 17-1/2
B	Ends (2)	3/4 x 7 x 9
C	Sides (2)	3/4 x 5 x 19
D	Handle	1-1/4 dia. x 18-1/4
	Flathead wood screws (22)	#9 x 1-1/2

1. Select your stock. Pressure-treated or a suitable outdoor wood such as redwood or cedar is best, but any scrap wood will do. The handle is standard 1-1/4" closet pole stock—or you can use part of an old broomstick.
2. Prepare the stock. Rip the bottom (A), ends (B), and sides (C) to width using a hand saw, then crosscut all pieces to length. Cut the contours on the ends (B) with a coping saw, and sand.
3. Drill the holes for the handle (D). Use a 1-1/4" Forstner bit to drill these 3/8" deep holes. Next, drill pilot holes for the assembly screws.
4. Assemble the toolbox with #9 x 1-1/2" flathead wood screws. Attach the ends (B) to the bottom (A) and insert the handle (D). Attach the sides (C). Round off all sharp edges with a rasp or sandpaper.

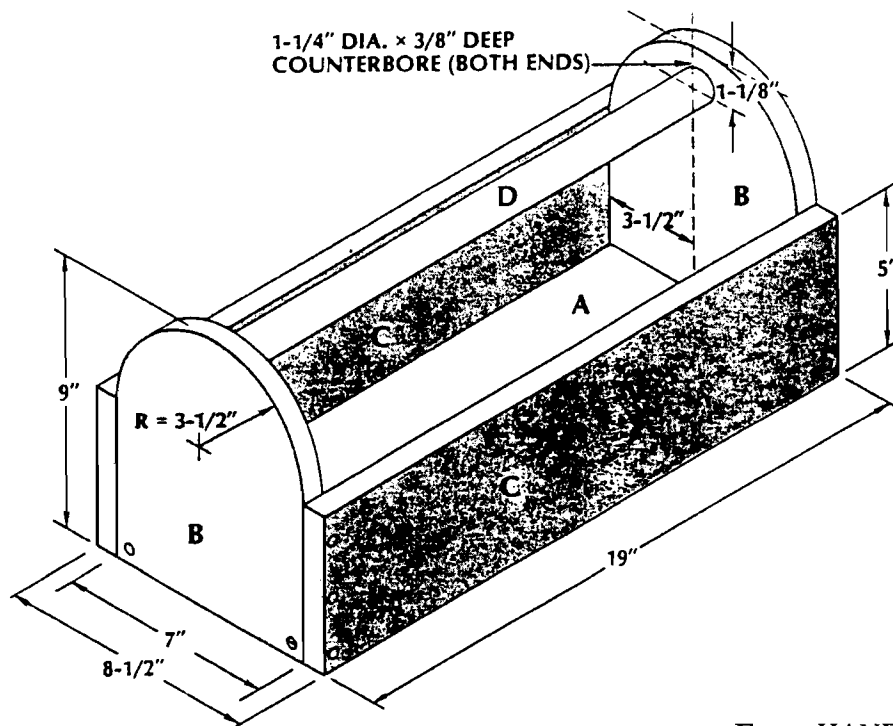

From *HANDS ON* June/July/Aug 84

LETTER & PENCIL HOLDER

Use to store pencils and mail.

Materials Needed:

- 2 x 4 x 5 1/2" (actual dimensions about 1 1/2" x 3 1/2" x 5 1/2"). 5/4" material may be used as an alternate.
- 1 x 2 x 6 3/4" (actual dimensions about 3/4" x 1 1/2" x 6 3/4")
- 1/4" plywood or paneling 3 3/4" wide and 6" long
- 3 - 8 penny finishing nails
- 3/4" wire brads
- Glue
- Finish materials

Tools Needed:

- Pencil
- Saw
- Square
- Hammer
- Bit brace (or electric drill) with 11/32" or 3/8" bit
- Hand drill (or electric drill) and headless 8 penny finishing nail (or drill bit of that size)
- Nail set

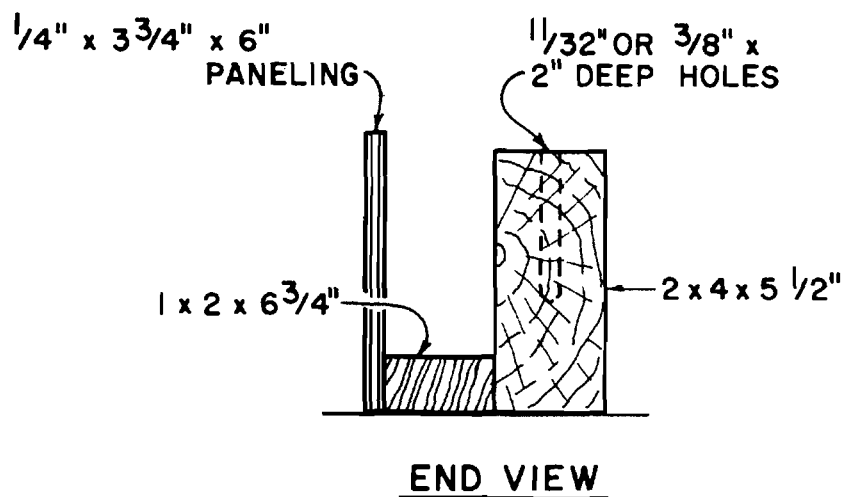
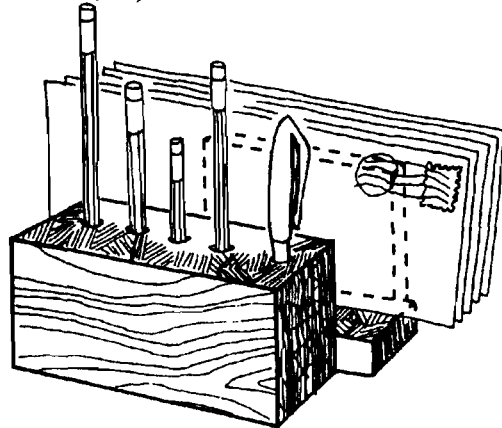

Hints:

- Mark centers of pencil holes on 2 x 45, 7/8" apart.
- Attach the 1 x 2 to the 2 x 4 with two finishing nails and glue. (Drill pilot holes for nails.)
- Attach the paneling or plywood to the 1 x 2 with 3/4" wire brads and glue.

TURTLE PUZZLE

Can be used as a toy and puzzle for youngsters ranging in age from 3 to 6 years.

Materials Needed:

- A piece of 5/4 or 2 x 4 material about 7" long. The 5/4 material is about 1 1/16" thick and the 2 x 4 is about 1 1/2" thick.
- Finish materials you select.

Tools Needed:

- Pencil and carbon paper
- Coping saw with coarse teeth
- Sandpaper (80 grit for rough surfaces and 120 grit for smooth surfaces)

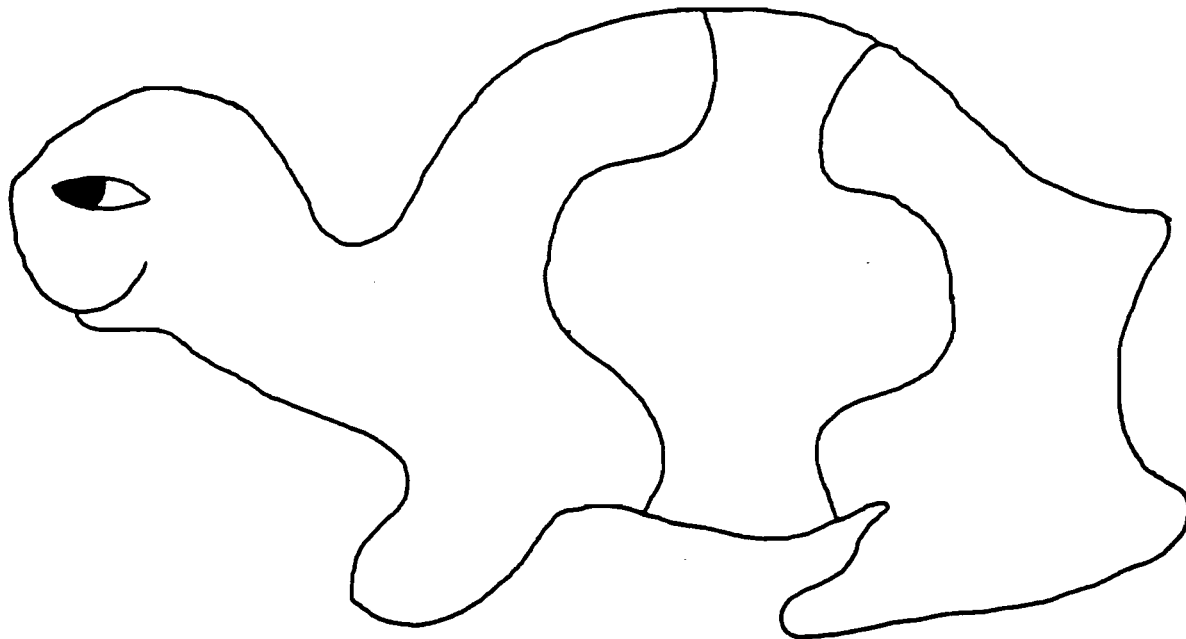
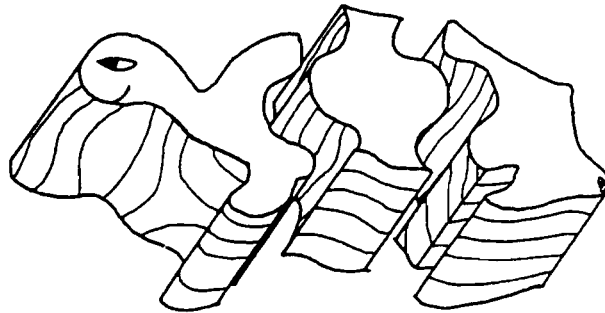

THE SHIFTING PYRAMID GAME

Materials Needed:

- 1 piece of 3/4" x 8" x 8" A-D or better plywood, or use a piece of lumber 1 x 10 (actual size 3/4" x 9 1/4") 8" long (base)
- 1 piece of 1/4" x 6" x 6" A-D or better plywood, or use a piece of lumber 1 x 8 (actual size 3/4" x 7 1/4") 6" long (game pieces)
- 1 piece of 1/4" dowel stock, 12" long (pegs)
- Glue
- Sandpaper (medium and fine grit)
- Finishing material (optional)

Tools Needed:

- Coping saw
- Boring tool with 1/4" and 3/8" bits

Instructions:

1. Trace the pattern for the base using carbon paper between your piece of wood and the pattern. Use the pattern on the next page.
NOTE: If your saw cuts on the pull stroke trace your pattern on the back side of your wood piece so that the front face of the piece does not get damaged during cutting.
2. Cut out the base using a saw.
3. Mark and drill 1/4" peg holes, 1/2" deep in the base at the locations marked with an X.
4. Sand the surfaces and edges of the base.
5. Cut three pieces of the 1/4" dowel stock, 3" in length.
6. Sand the dowel pegs rounding the top ends.
7. Apply glue to the sides of the holes with a small stick, then place the pegs in the holes.
8. Mark and cut the five movable pieces from the 1/4" plywood. Dimensions of the pieces are (3" x 3") (2 1/2" x 2 1/2") (2" x 2") (1 1/2" x 1 1/2") and (1" x 1"). These pieces can be cut round or square.
9. Mark the centers of each individual piece and drill a 3/8" hole completely through the piece.
10. Sand each piece and finish with a material of your choice. Painting the pieces different colors adds eye appeal.

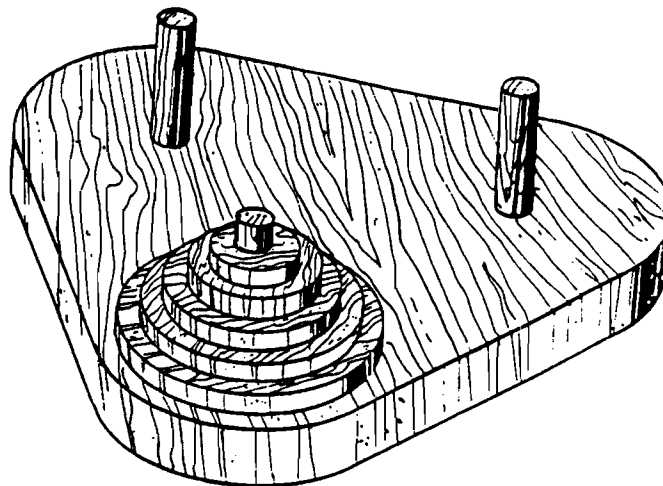

How to Play:

Place five pieces on one peg in pyramid formation. The object is to shift the entire pyramid (5 pieces) to another peg moving one piece at a time and at no time having a larger piece above a smaller one. Can you do it in 31 move—that's perfect?

To make the puzzle more challenging use seven blocks instead of five.

Actual Size of
Base Pattern

X

X

X

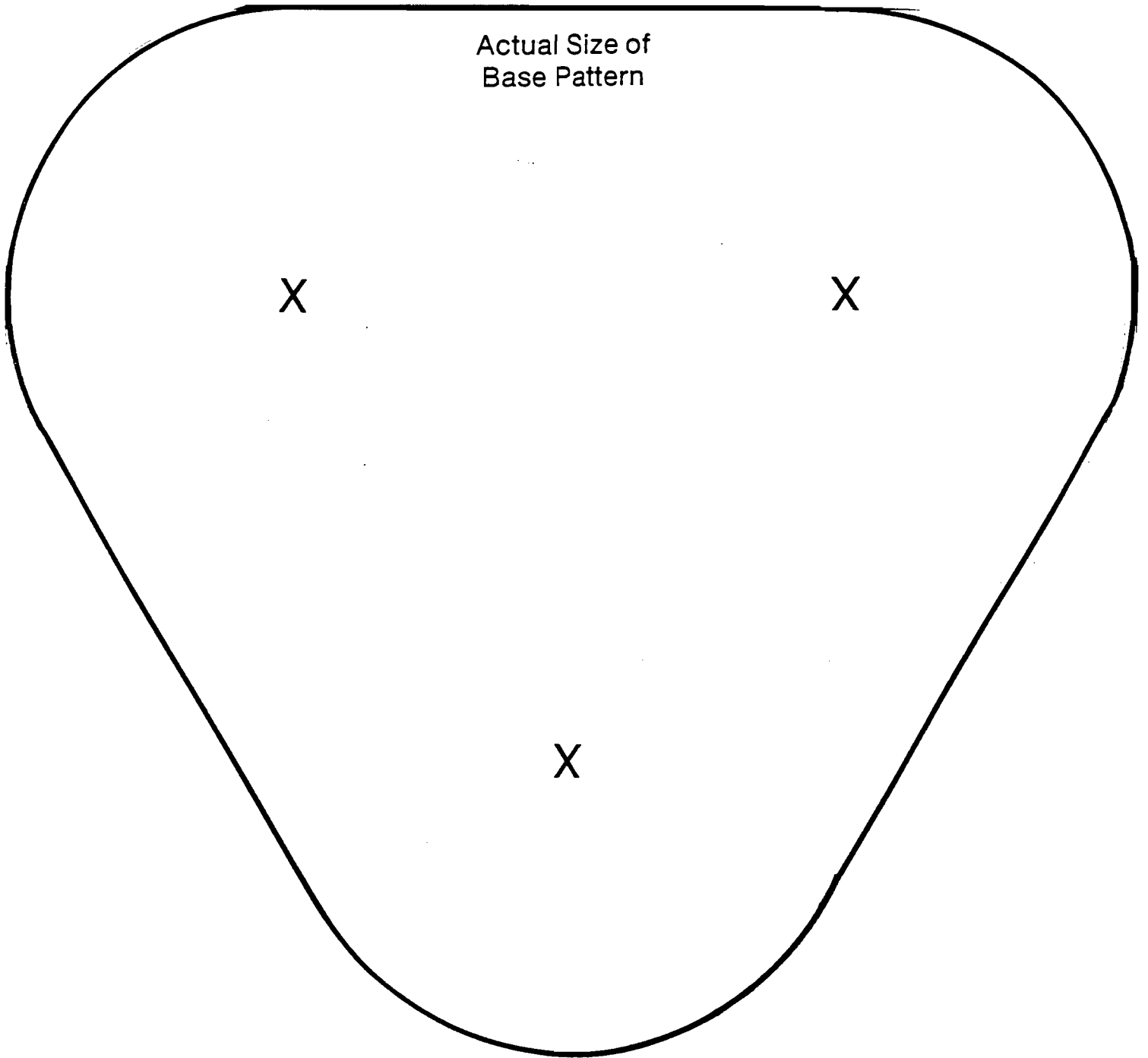

NINE BLOCK PUZZLE

Construct shallow box in proportion of 4 inches by 5 inches inside measurements with 1/4 inch trim around the edges. Entire puzzle may be built from 1/4 inch plywood. The model shown is: (1) 2 inches by 2 inches, (2-3) 1 inch by 1 inch, (4-5-6-7-8-9) 1 inch by 2 inches. An extra 1/16 inch is allowed on inside base for ease of moving blocks. Overall size is 4 9/16 inches by 5 9/16 inches with 1/4 inch trim.

Countersink holes in blocks at dots for easy moving.

Puzzle: Move large block (1) from upper right corner to position of (8) and (9).

Key to solution: Small blocks move around the board in clockwise fashion. Do not get the large block in either of the lower corners.

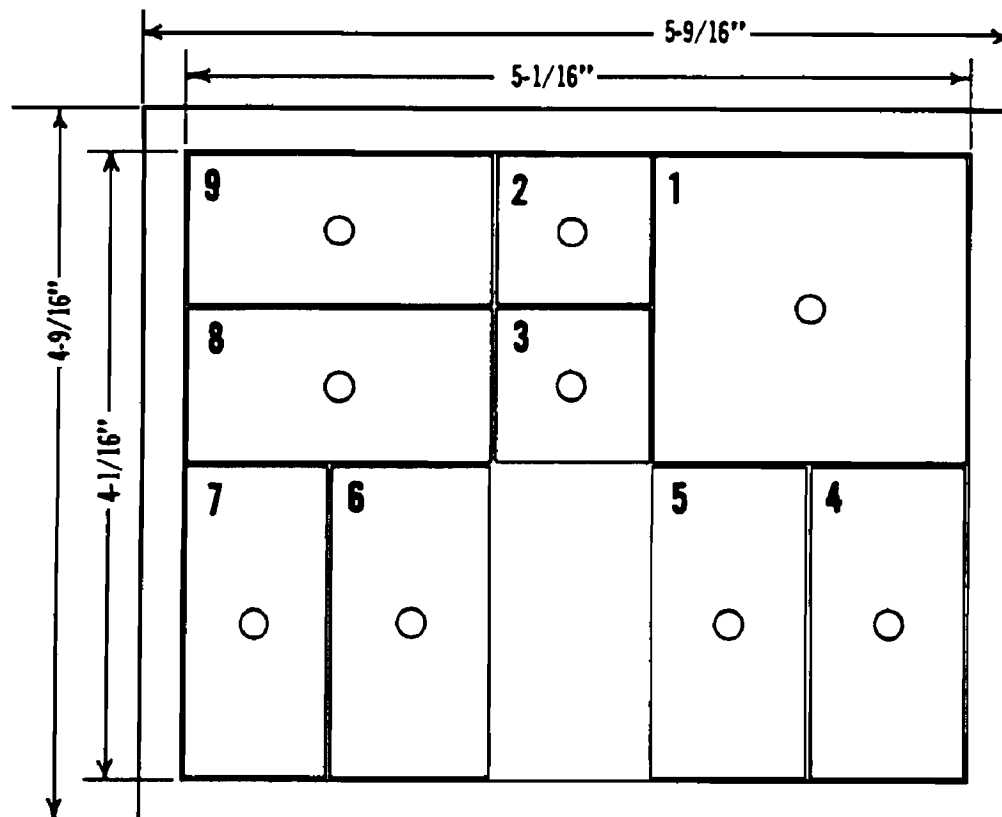

LETTER HOLDER

Materials Needed:

- One piece of 1 x 2 (actual dimensions approximately 3/4" x 1 1/2") 6" long
- Enough plywood or paneling to cut 2 pieces each 4" x 6"
- Eight - 1" wire brads
- Glue
- Finish materials

Tools Needed:

- Square
- Pencil
- A saw for square-cuts
- A coping saw for curve cuts
- Pencil compass
- Hammer
- Nail set
- Sandpaper (80 grit for rough wood and 120 grit for smooth wood)

Instructions:

1. Cut the center piece of the 6" length.
2. Mark the cutout lines for the side pieces. Remember, most plywood and paneling has one side better than the other side. Arrange your pieces so the best side of the plywood will be the outside of both the front and back piece. You may want to clamp both pieces together and cut both at the same time. *Other Ideas:* Add designs or decals to the side pieces. Use different material. Change the shape. Make it larger for a napkin holder.

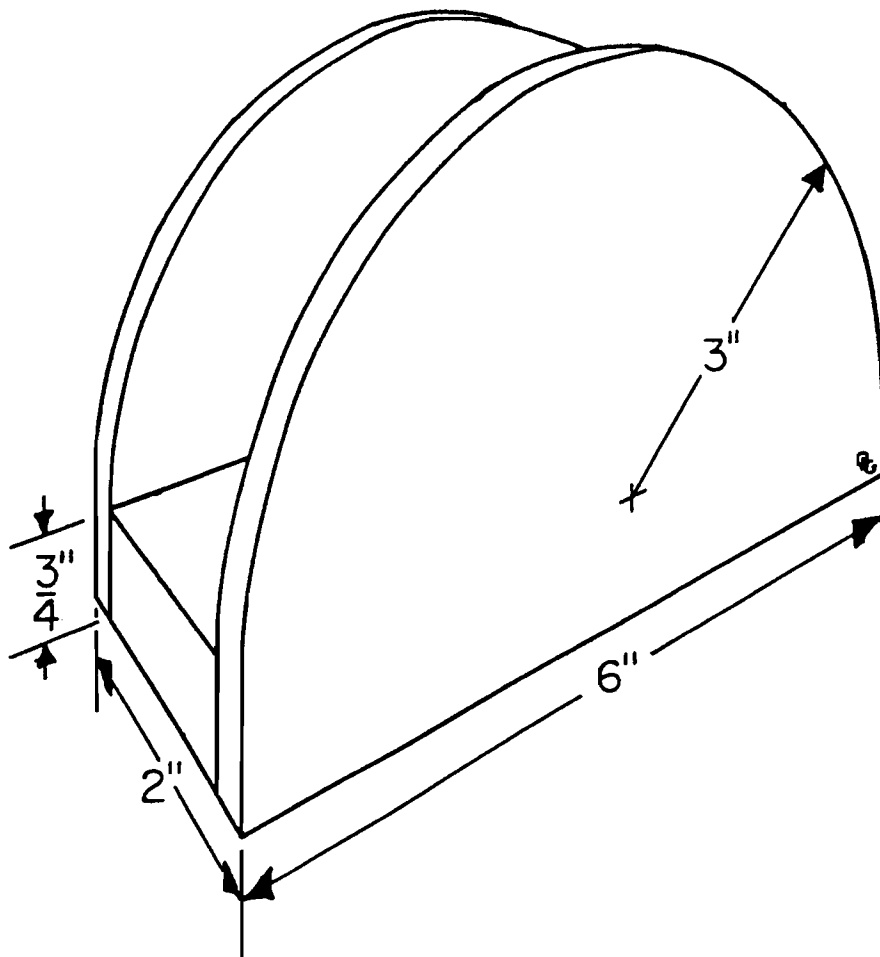

NAIL AND SCREW HOLDER

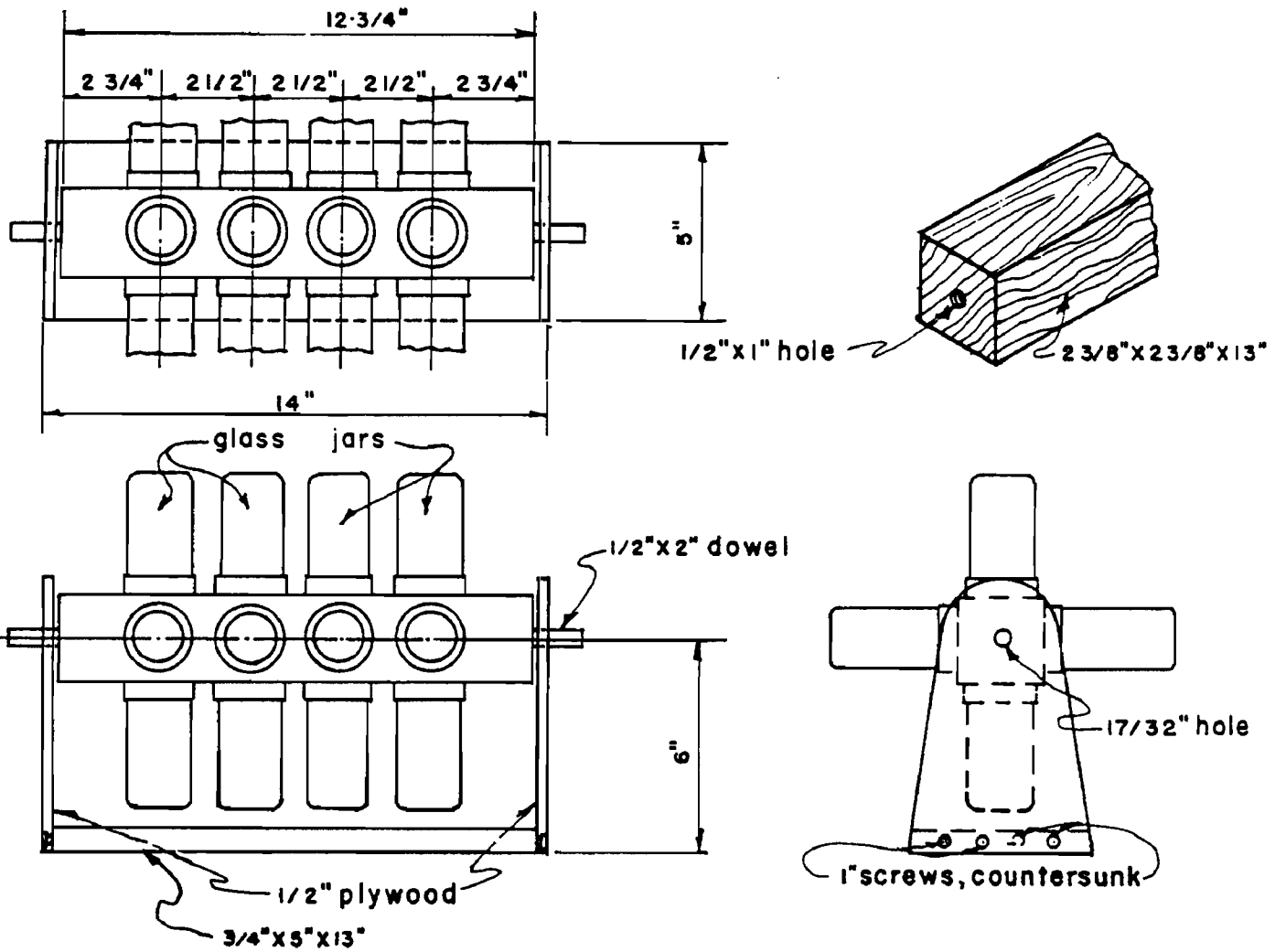

NOTE: Screw the jar lids onto the block on all four sides.

HORSESHOE TIE RACK

Materials Needed:

- One piece of lumber or plywood 6" x 6" about 3/4" thick
- One piece of wood 1/8" x 3/8" x 4"
- Seven 2" horseshoe or cut iron nails
- One small screw eye
- 1/2" wire brads
- Interior finish materials

Tools needed:

- Pencil
- Saw
- Drill
- Sandpaper
- Hammer
- Brush

Instructions:

1. Cut out the horseshoe and cleats.
2. Attach the cleats with glue and wire brads.
3. Drill pilot holes for the horseshoe or cut iron nails.
4. Sandpaper smooth.
5. Apply finish.
6. Drive in nails to equal height.

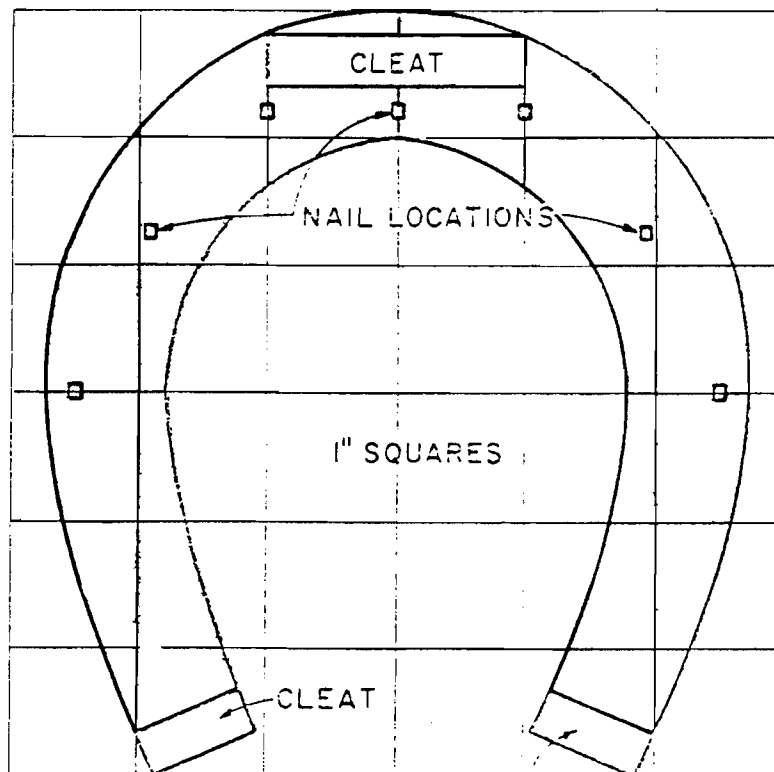
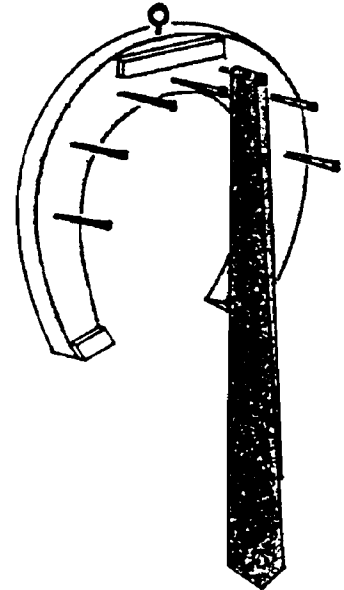

3/8" FIBERBOARD
OR WOOD CLEAT

HALF SHELF

Materials Needed:

- 1—1 inch by 6 inches in length to suit conditions
Use 1/2 inch plywood with 3/4 inch uprights if paint or enamel is finishing material.

Hardware Needed:

- Short shelves do not need corner bracing
- Corner braces are needed if shelves are over 16 inches
- Glue for all joints
- Nails as needed

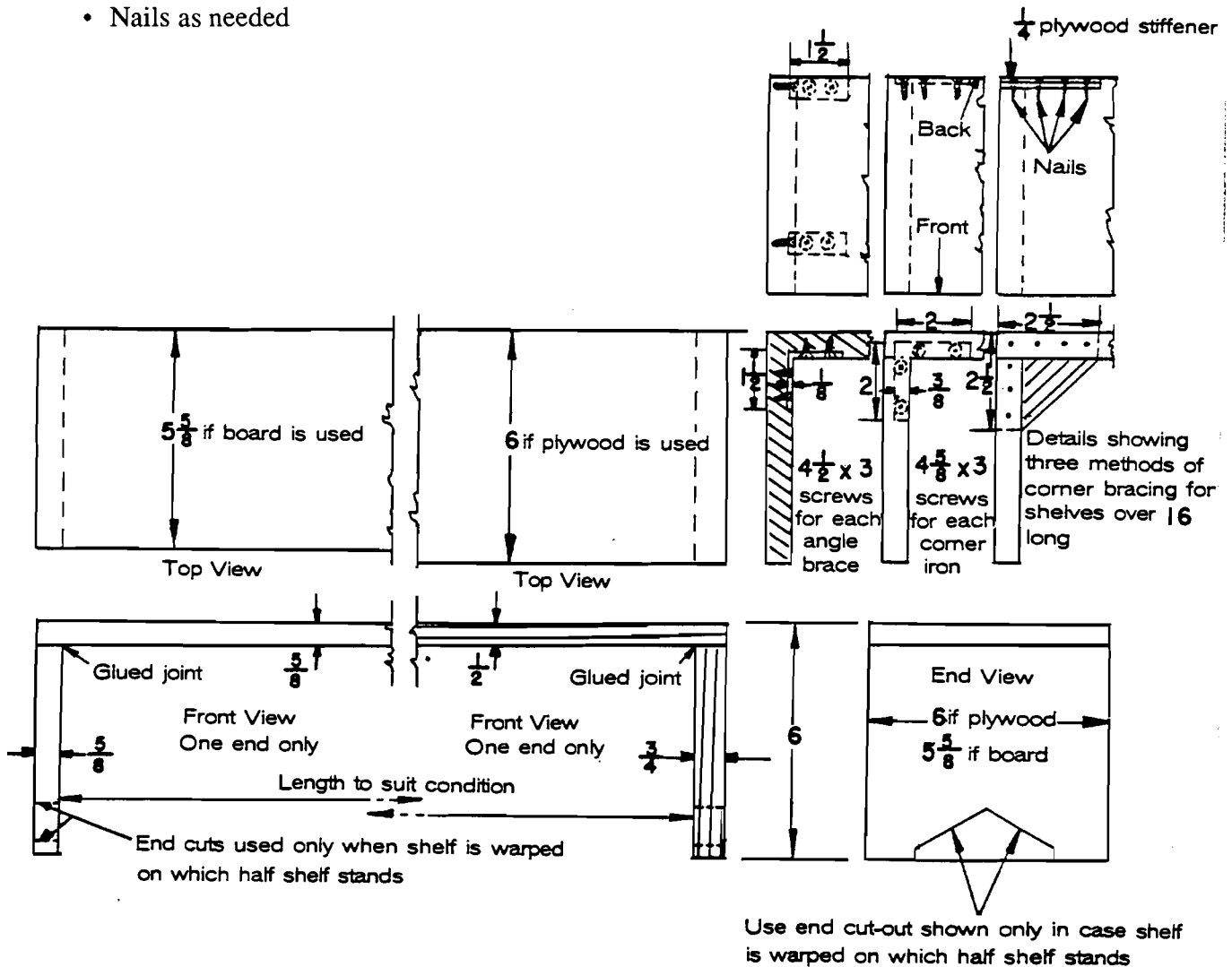

4-H BOOK ENDS

Materials Needed:

- 1 piece of 1 x 6 lumber (actual size 3/4" x 5 1/2") and 36" long or you can use interior type plywood (3/4" A-C grade or better)
- 10—1 1/2" finishing nails
- Sandpaper (medium and fine grit)
- Glue
- Paint and varnish, optional

Tools Needed:

- Coping saw
- Hammer

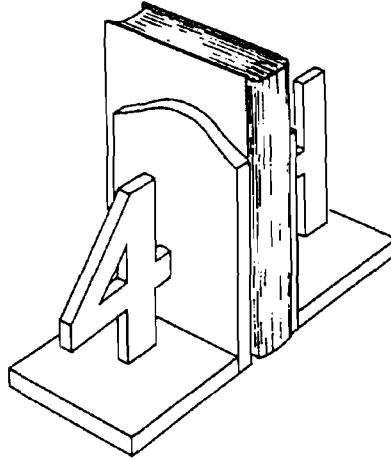

Instructions:

1. Mark out two base pieces 5 1/4" long. Mark out the end pieces and the 4 and H. They can be traced with carbon paper and pencil.
2. Cut out the pieces and sandpaper smooth. Put together with 1 1/2" finishing nails and glue.
3. Apply finish.

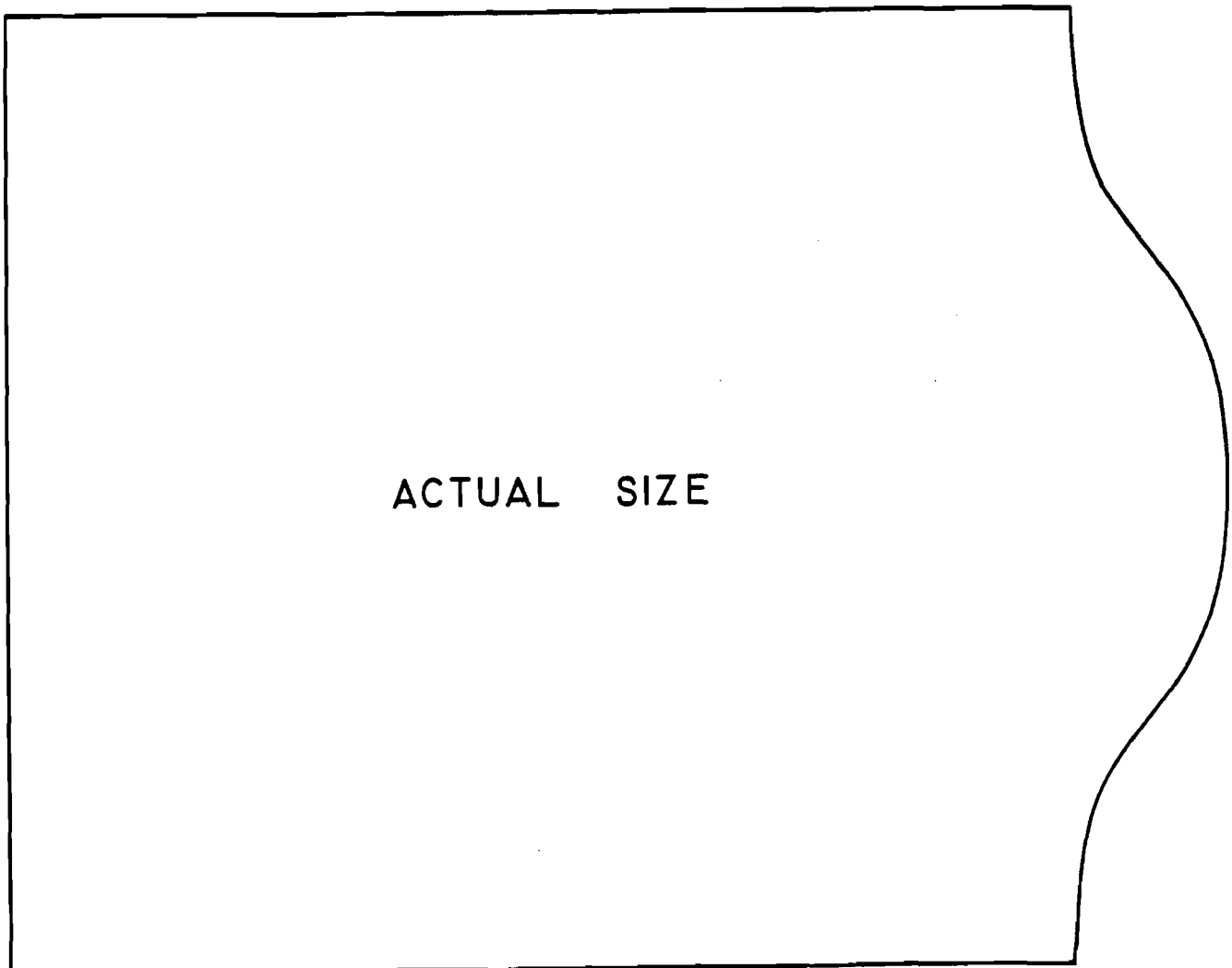

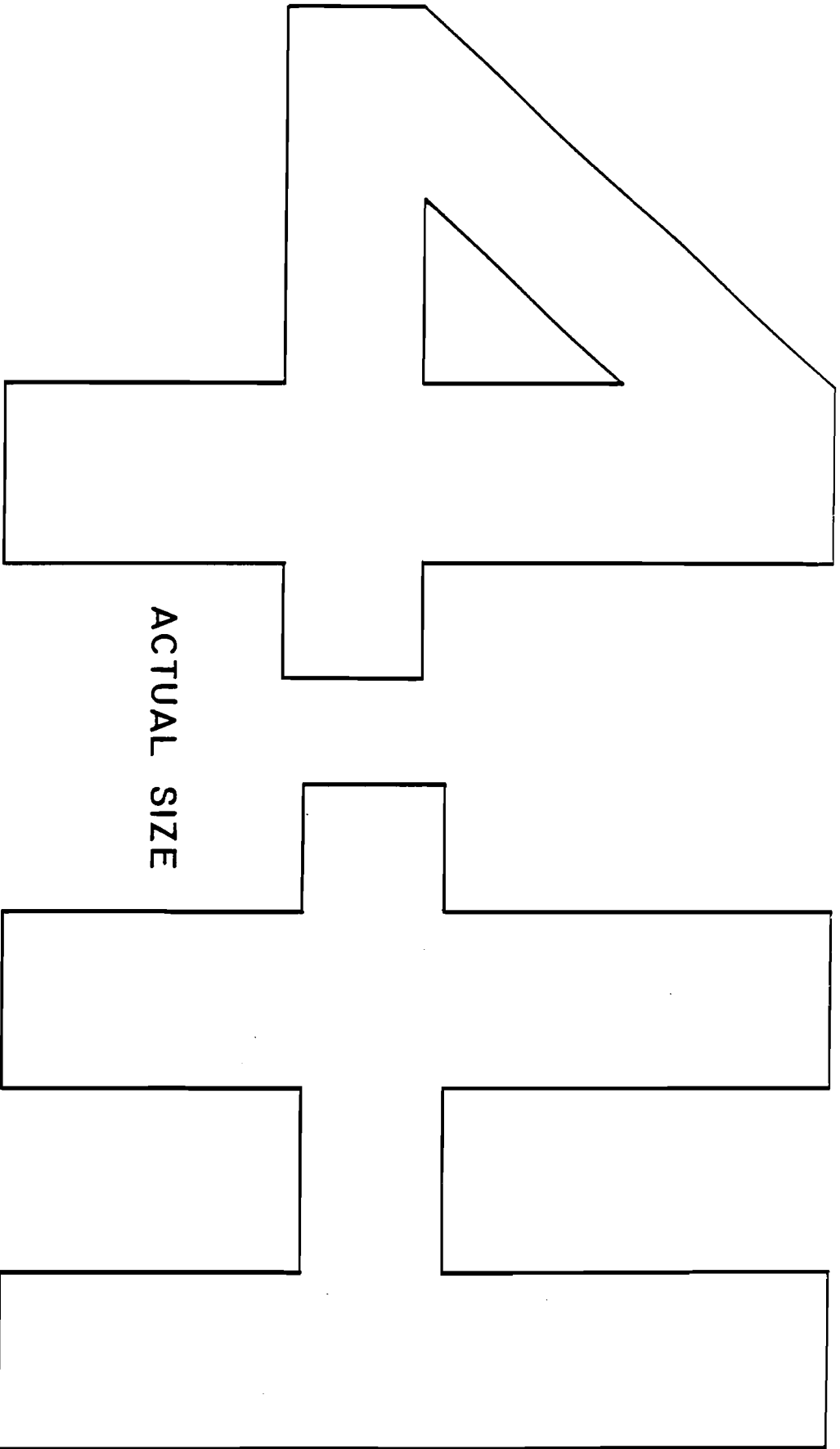

BROOM HOLDER

Materials Needed:

- 2 pieces of lumber 1" x 4" x 10"
- 4—#5 flathead wood screws 1 1/4" long
- Enamel or varnish finish

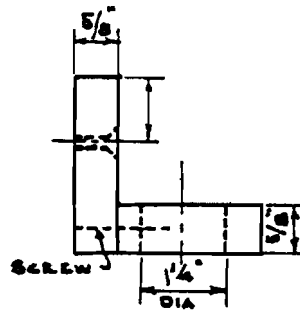
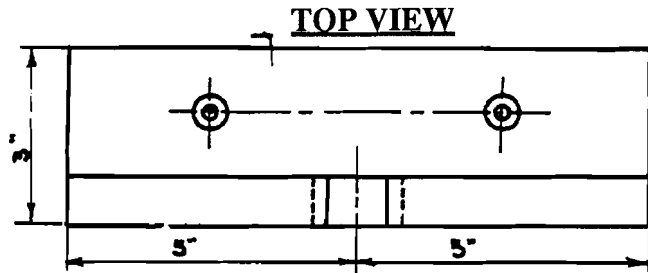
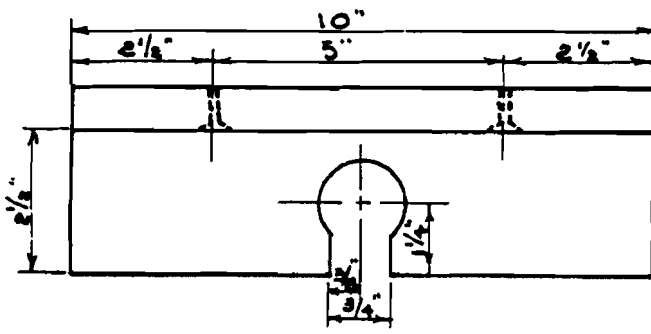
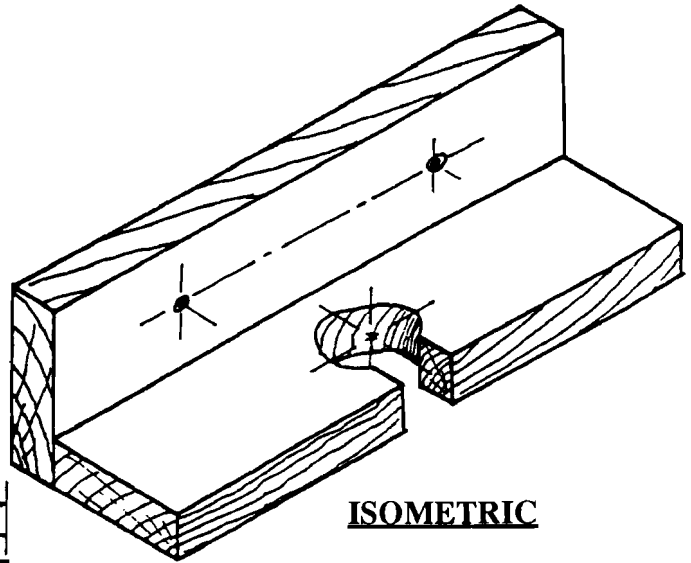

CANDLE HOLDERS

Materials Needed:

- 2 x 4 material for the single block 1 1/2" thick. Actual dimensions of the 2 x 4 is about 1 1/2" x 3 1/2".
- 1 x 4 material (actual dimensions about 3/4" x 3 1/2" for the multipiece unit)
- 1" wire brads and glue for the multi-piece unit
- Finish materials you select

Tools Needed:

- Square
- Pencil
- Saw
- Drill for 3/4" hole
- Sandpaper (80 grit for rough surfaces and 120 grit for smooth surfaces)

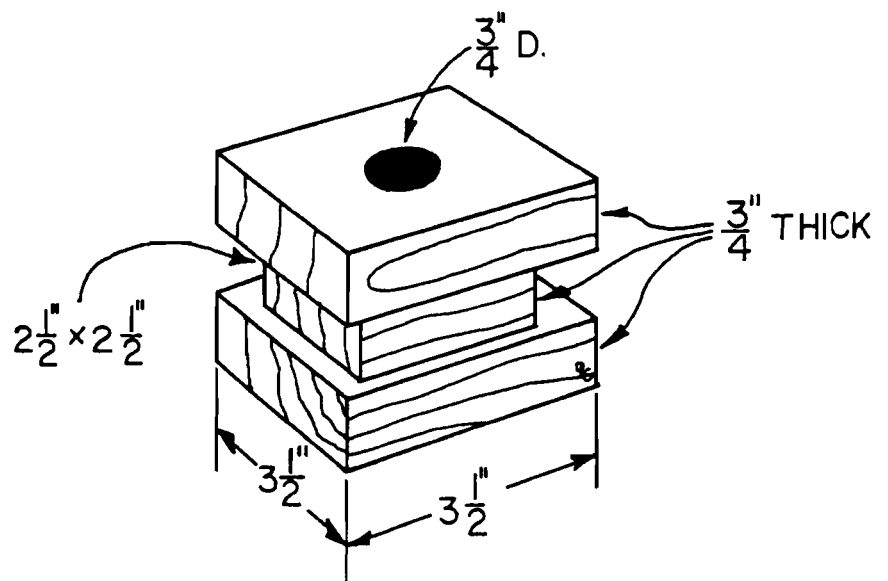
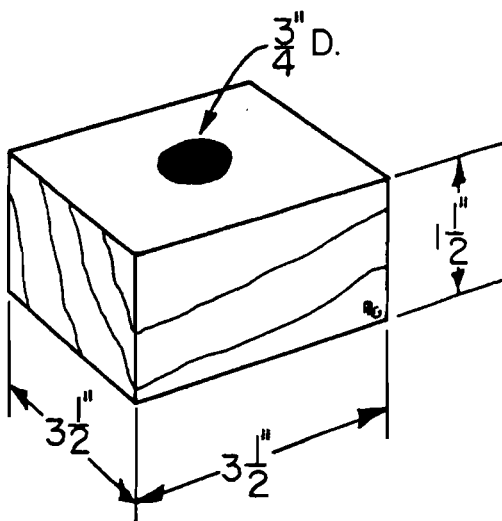

COPING SAW PUZZLE

Materials Needed:

- A piece of 1/4" plywood or paneling or 1/4" medium density hardboard about 6" x 8"
- One plastic or paper bag or large envelope to hold the completed puzzle

Tools Needed:

- Square
- Pencil
- Saw for square cuts
- A coping saw for curved cuts

Instructions:

1. Draw a wavy line around the piece near the edge. Keep the line at least 1 1/4" from the edge.
2. Cut along this line to cut out the center piece.
3. Draw more wavy lines on the center piece for the puzzle.
4. Cut along these lines to make your puzzle. Put each piece in the paper bag or envelope. Do not lose any of the puzzle.

Other Ideas:

- Use your imagination. Glue or cement a picture or drawing on the work-piece before cutting it.
- Cut a second board to the exact same size as the first board. Cut the outer piece of the puzzle from the first board and attach to the second board.

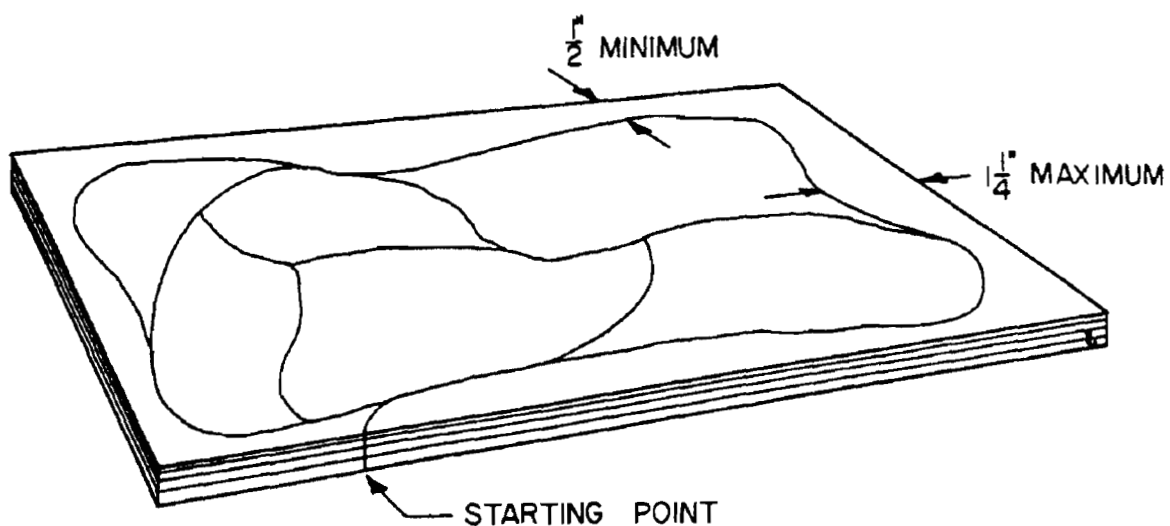

CUTTING BOARD

Materials Needed:

- 1 piece of 1 x 8 hardwood (actual size $3/4$ " x $7 1/4$ ") 15" long
- Sandpaper (medium and fine grit)
- Varnish

Tools Needed:

- Pencil compass
- Square
- Coping saw
- Boring tool with $1/4$ " bit

Instructions:

1. Using the pencil compass, lay out curves and hole in handle on your wood piece. Use the square to make straight lines on the sides and end.
2. Cut out the curves and drill hole.
3. Sand both sides.
4. Finish with two or three coats of varnish, one side only. This process is optional.

Note: After each coat of varnish, lightly sand before applying the next coat of varnish.

